

Unical

MODAL



BREVETTO
Unical
PATENT

smoke pipes

PRESSURIZED STEEL BOILER WITH REVERSED FLAME

OUTPUT RANGE

from 64 to 291 kW

WORKING TEMPERATURE

minimum return temperature higher than 50°C

OPERATION WITH

gas or oil fired pressure jet burners

MODELLE

64

76

93

105

116

140

163

186

233

291

Decentralization of tube bundle for high resistance to the condensate

MAIN COMPONENTS

1. Furnace
2. Smoke pipes with smoke diverters
3. Door with flame control warning light
4. Smoke chamber
5. Body insulation
6. Panel board

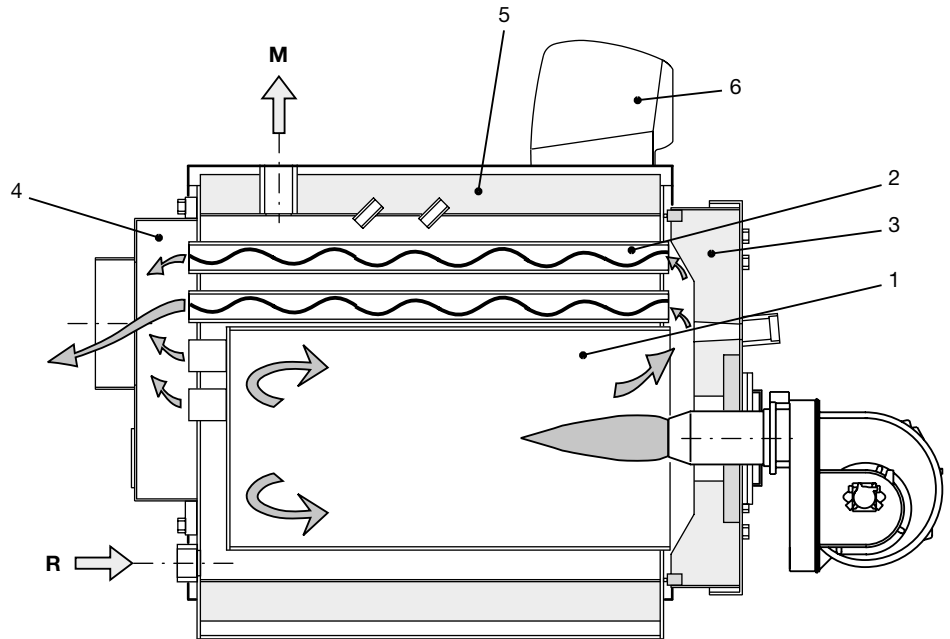

TECHNICAL DATA

MODAL		64	76	93	105	116	140	163	186	233	291
NOMINAL OUTPUT	kW	64	76	93	105	116	140	163	186	233	291
NOMINAL INPUT	kW	71	84	102	115	128	155	180	206	258	322
WATER EFFICIENCY AT NOMINAL LOAD	%	90.1	90.4	91.1	91.3	90.6	90.3	90.5	90.3	90.3	90.4
BOILER CAPACITY	l	86	86	86	126	126	126	151	151	203	247
WATER PRESSURE DROPS*	m w.c.	0.10	0.13	0.16	0.10	0.10	0.14	0.20	0.25	0.22	0.30
FLUE GAS PRESSURE DROP	mm w.c.	1.5	1.8	2.5	3	3	5	8	14	18	22
MAXIMUM BOILER WORKING PRESSURE**	bar	6	6	6	6	6	6	6	6	6	6
WEIGHT	kg	195	195	195	280	280	280	318	318	420	480

*Pressure drops corresponding to a thermal variation of 15K. **On request, available up to 10 bar.

PRODUCT PLUS VALUES

- **COMPACT DIMENSIONS**
simplifies the transport and the positioning in boiler house
- **THERMAL EXCHANGE OPTIMISATION**
by driven water passage into the boiler
- **TUBE BUNDLE POSITIONING**
decentralized upwards, above the furnace, with drastic reduction of the possible condensation
- **SMOKE PIPES OF HIGH THICKNESS**
with anti-condensing effect
- **TURBULATORS**
for the thermal exchange optimisation into the smoke pipes
- **BOTTOM OF THE FURNACE**
reinforced with U profiles for greater mechanical resistance
- **INTERNAL DOOR INSULATION**
in light refractory concrete
- **FRONT DOOR**
with self-centering locking
- **EXTERNAL CASING**
inclusive of 60 mm rock wool insulation
- **PANEL BOARD**
suitable for electronic control

DIMENSIONS

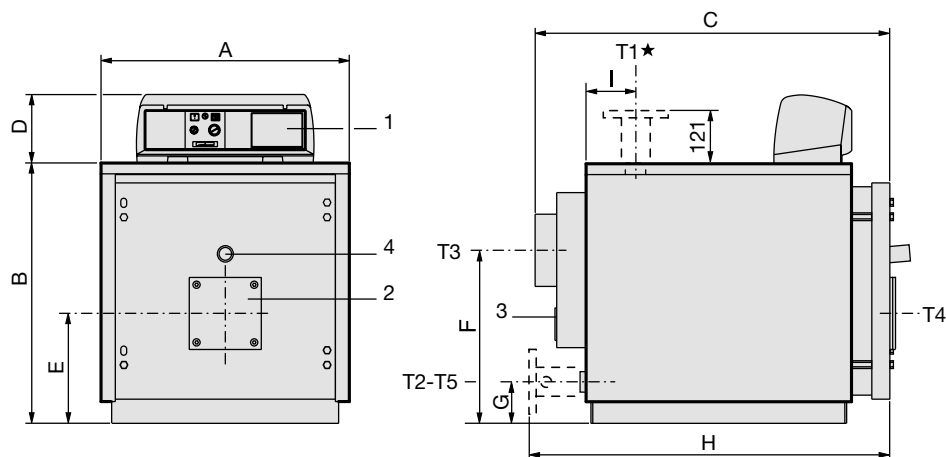

- 1 Board panel
- 2 Burner connection plate
- 3 Cleaning door
- 4 Sight glass
- T1 C.H. flow
- T2 C.H. return
- T3 Flue connection
- T4 Burner axis
- T5 Boiler drain

MODAL	Nominal output kW	Nominal input kW	Boiler capacity l	Water pressure drops(**) m w.c.	Flue gas pressure drop mm w.c.	Maximum boiler working pressure bar	Weight kg	CONNECTIONS			
								T1 - T2 ISO 7/1 UNI2278 PN16 Rp 1½	T3 Øe mm	T4 Øi mm	T5 Øi ISO 7/1 Rp ¾
64	64	71	86	0.10	1.5	6	212	Rp 1½	200	130	Rp ¾
76	76	84	86	0.13	1.8	6	212	Rp 1½	200	130	Rp ¾
93	93	102	86	0.16	2.5	6	212	Rp 1½	200	130	Rp ¾
105	105	115	126	0.10	3	6	309	Rp 2	200	180	Rp ¾
116	116	128	126	0.10	3	6	309	Rp 2	200	180	Rp ¾
140	140	155	126	0.14	5	6	309	Rp 2	200	180	Rp ¾
163	163	180	151	0.20	8	6	349	Rp 2	200	180	Rp ¾
186	186	206	151	0.25	14	6	349	Rp 2	200	180	Rp ¾
233	233	258	203	0.22	18	6	485	DN 65*	250	180	Rp ¾
291	291	322	247	0.30	22	6	555	DN 65*	250	180	Rp ¾

MODAL	A mm	B mm	C mm	D mm	E mm	F mm	G mm	H mm	I mm
64	690	722	990	190	305	480	115	--	147
76	690	722	990	190	305	480	115	--	147
93	690	722	990	190	305	480	115	--	147
105	760	812	1205	190	350	500	130	--	157
116	760	812	1205	190	350	500	130	--	157
140	760	812	1205	190	350	500	130	--	157
163	760	812	1385	190	350	500	130	--	157
186	760	812	1385	190	350	500	130	--	258
233	860	937	1437	190	421	580	165	1482	258
291	860	937	1687	190	421	580	165	1732	258

(*) In the MODAL 233 and MODAL 291 models, connections T1 and T2 are flanged.

(**) Pressure drops corresponding to a thermal variation of 15K.

BURNER BLAST TUBE DIMENSIONS

BOILER TYPE	øA mm	L mm
MODAL 64÷93	130	150
MODAL 105÷140	180	170
MODAL 163÷186	180	170
MODAL 233÷291	180	170

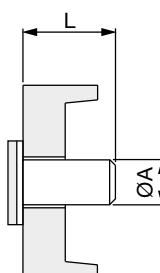

TECHNICAL DATA

ELECTRICAL, HYDRAULIC, INSTALLATION DIAGRAMS AND CONTROLLERS can be unloaded from the web site www.unical.eu at the page of the product

Gas fired		MODAL 64	MODAL 76	MODAL 93	MODAL 105	MODAL 116
Nominal output	kW	64.0	76.0	93.0	105.0	116.0
Nominal input	kW	71.0	84.0	102.0	115.0	128.0
Water efficiency at full load (100%)	%	90.1	90.4	91.1	91.3	90.6
Water efficiency at part load (30%)	%	85.4	85.6	85.9	86	86.1
Efficiency class (ex dir. 92/42 CEE)		1	1	1	1	1
Combustion efficiency at nominal load (100%)	%	90.6	91	91.6	91.8	91.1
Casing heat losses (80°-60°C)	%	0.5	0.5	0.5	0.5	0.4
Chimney losses with burner on	%	9.3	8.9	8.3	8.1	8.9
Chimney losses with burner off	%	0.2	0.2	0.2	0.2	0.2
Net flue gas temperature tf-ta	°C	187.0	180.4	169.2	167.3	182.3
CO ₂ content	%	9.5	9.6	9.7	9.8	9.8
Flue gas mass flow rate	kg/h	109.0	128.5	154.7	172.9	192.4

Gas fired		MODAL 140	MODAL 163	MODAL 186	MODAL 233	MODAL 291
Nominal output	kW	140.0	163.0	186.0	233.0	291.0
Nominal input	kW	155.0	180.0	206.0	258.0	322.0
Water efficiency at full load (100%)	%	90.3	90.5	90.2	90.3	90.3
Water efficiency at part load (30%)	%	86.4	86.6	86.8	87.1	87.3
Efficiency class (ex dir. 92/42 CEE)		1	1	1	1	1
Combustion efficiency at nominal load (100%)	%	90.8	91.2	91	91	90.8
Casing heat losses (80°-60°C)	%	0.5	0.6	0.7	0.7	0.5
Chimney losses with burner on	%	9.1	8.7	8.9	8.9	9.1
Chimney losses with burner off	%	0.2	0.2	0.2	0.2	0.2
Net flue gas temperature tf-ta	°C	187.9	179.5	184.2	183.2	187.0
CO ₂ content	%	9.8	9.8	9.8	9.8	9.8
Flue gas mass flow rate	kg/h	233.0	270.6	309.6	387.8	484.0

Oil fire		MODAL 64	MODAL 76	MODAL 93	MODAL 105	MODAL 116
Nominal output	kW	64.0	76.0	93.0	105.0	116.0
Nominal input	kW	71.0	84.0	102.0	115.0	128.0
Water efficiency at full load (100%)	%	90.1	90.4	91.1	91.3	90.6
Water efficiency at part load (30%)	%	85.4	85.6	85.9	86	86.1
Efficiency class (ex dir. 92/42 CEE)		1	1	1	1	1
Combustion efficiency at nominal load (100%)	%	90.6	91	91.6	91.7	91.1
Casing heat losses (80°-60°C)	%	0.5	0.5	0.4	0.4	0.4
Chimney losses with burner on	%	9.3	8.9	8.3	8.2	8.9
Chimney losses with burner off	%	0.2	0.2	0.2	0.2	0.2
Net flue gas temperature tf-ta	°C	200.0	193.0	181.0	179.0	195.0
CO ₂ content	%	12.4	12.5	12.6	12.7	12.8
Flue gas mass flow rate	kg/h	111.4	131.6	158.6	177.4	196

Oil fire		MODAL 140	MODAL 163	MODAL 186	MODAL 233	MODAL 291
Nominal output	kW	140.0	163.0	186.0	233.0	291.0
Nominal input	kW	155.0	180.0	206.0	258.0	322.0
Water efficiency at full load (100%)	%	90.3	90.5	90.2	90.3	90.3
Water efficiency at part load (30%)	%	86.4	86.6	86.8	87.1	87.3
Efficiency class (ex dir. 92/42 CEE)		1	1	1	1	1
Combustion efficiency at nominal load (100%)	%	90.8	91.2	91	91	90.8
Casing heat losses (80°-60°C)	%	0.5	0.6	0.7	0.7	0.5
Chimney losses with burner on	%	9.1	8.7	8.9	8.9	9.1
Chimney losses with burner off	%	0.2	0.2	0.2	0.2	0.2
Net flue gas temperature tf-ta	°C	201.0	192.0	197.0	196.0	200.0
CO ₂ content	%	12.8	12.8	12.8	12.8	12.8
Flue gas mass flow rate	kg/h	237.4	275.6	315.4	395.1	493.1